

**INSTRUCTIONS FOR INSTALLING A BASE PLATE AND ACCESSORY ASSEMBLY**

**CHECK THE PARTS RECEIVED IN THE KIT WITH THE PARTS LIST  
IN THESE INSTRUCTIONS. IF ANY PARTS ARE MISSING,  
CONTACT NATIONAL VENDORS' PARTS DEPARTMENT IMMEDIATELY.**

Read these instructions carefully before installing the kit.  
Retain these instructions for part numbers and for future reference.

These kits contains the following:

<b>KIT PART NUMBER</b>	<b>INSTRUCTION</b>	<b>LOOSE PARTS BAG ASSEMBLY</b>	<b>BASE PLATE ASSEMBLY</b>
1571085	1571086	1571087	1571025 (38")
1581022	1571086	1571087	1581025 (32")
4251218	1571086	1571087	4251030 (56")
4311065	1571086	4311066	1571025 (38")
4851035	1571086	1571087	4851025 (40")

**PARTS INCLUDED IN THE LOOSE PARTS BAG ASSEMBLIES**

<b>LOOSE PARTS</b>	<b>LOOSE PARTS BAG ASSEMBLY</b>		
	<b>QTY</b>	<b>1571087</b>	<b>4311066</b>
Base plate bracket	2	1571027	1571027
Base plate slide - RH	1	1411194	4301511
Base plate slide - LH	1	1411195	4301512
Cotter pin	2	9900098	9900098
Screw #8-32 x .31 Hex Head	4	1451097	1451097

## **INSTALLING A BASE PLATE AND ACCESSORY ASSEMBLY ON ALL MODEL MERCHANDISERS**

Refer to Figure 1 while completing the following procedure:

1. Secure two base plate brackets to the bottom of the merchandiser using the two #8-32 screws.
2. Insert the short arms of the slides into the hinged tabs of the base plate. Position the slide so the notch near the short arm is on the bottom side.
3. Insert the long arms of the slides into the base plate brackets.
4. Insert and secure a cotter pin through the hole in the back of each of the slides.
5. Push the base plate toward the merchandiser cabinet. The front tabs of the base plate brackets should seat in the notches in the long arms of the slides.

### **TYPICAL BASE PLATE INSTALLATION**

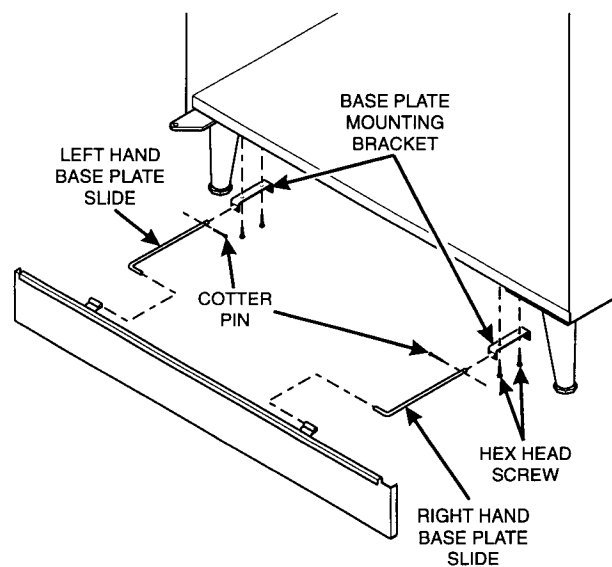

**Figure 1**

### **CAUTION**

The base plate mounting brackets are subject to damage when moving the merchandiser with a fork lift.

**Remove the base plate mounting brackets prior to moving the merchandiser with a fork lift.**